

INSTALLATION, OPERATION & MAINTENANCE MANUAL

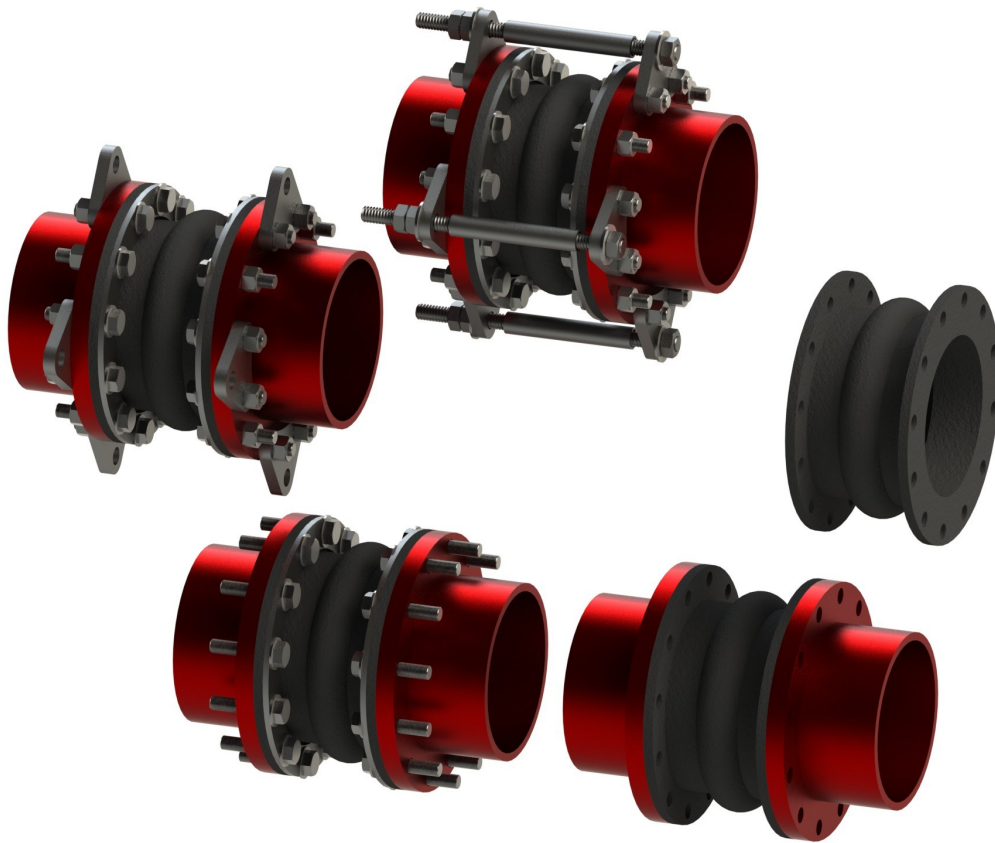

Date:



*The Expansion Joint
and
Check Valve People*

2431 North Wigwam Dr.
Stockton, CA 95205
Phone: 800-344-3246
Fax: 209-943-0242
Email: sales@procoproducts.com



Table of Contents

1.0 Introduction	2
2.0 Storage and Handling	2
3.0 Prior to Installation	3
4.0 Expansion Joint Installation	6
5.0 System Testing	12
6.0 Operating and Maintenance Procedures	12
7.0 Trouble Shooting	14
APPENDIX A: Torque Data	15
APPENDIX B: Installation Record Sheet	17



1.0 Introduction:

Proco Products, Inc. (Proco) rubber expansion joints are flexible connectors fabricated of natural or synthetic elastomers and fabrics, and if necessary metallic reinforcements to provide stress relief in piping systems due to thermal and mechanical vibrations and/or movements. This installation, operation and maintenance manual will cover the general practices for the proper installation, operation and maintenance of the Proco “Spool Type” rubber expansion joints. The Proco Spool Type rubber expansion joints covered in this guide include the Series 230, Series 231/BT, Series 251/BT, Series 261R, and Series 271 which all contain integrated full flat faced flanges as shown in Figure 1.

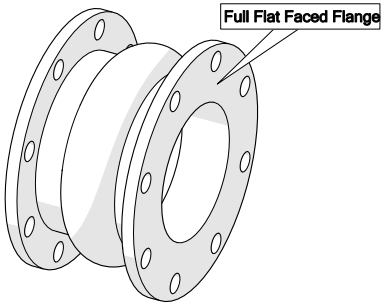

Figure 1: Spool Type (Integral full flat faced flange)

2.0 Storage and Handling:

2.1 Storage:

2.1.1 Inside:

The ideal storage for an expansion joint is in a warehouse setting with a relatively dry and cool location. Store the flanged expansion joint face down on a pallet or wooden platform. Do not lay other boxes on top of expansion joint or expansion joint box.

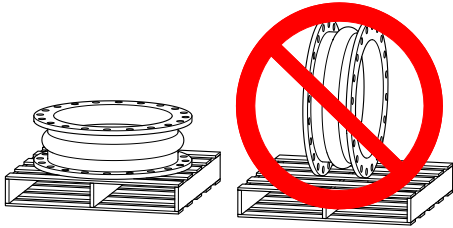

Figure 2: Proper Storage Position (Left), Incorrect (Right)

2.1.2 Outside:

If the expansion joint is to be stored outside, keep the expansion joint protected in a waterproof protected crate until ready for installation into the system. Also keep the expansion joint protected from any external elements such as direct UV exposure and/or animals from nesting. Do not lay other boxes on top of expansion joint or expansion joint box.

2.2 Large Joint Handling:

In the case of large size expansion joints, special care should be taken in loading, hoisting and lowering, being careful not to hit against adjacent equipment, forklift tines, crane cables, etc. Do not lift expansion joints with rope or bars through the bolt holes. Lift utilizing nylon slings around the exterior of the expansion joint as shown in Figure 3. Position the slings to the side of the arch/arches and not over the arch to prevent any damage to the arch as well as to ensure that the weight is evenly distributed during installation.

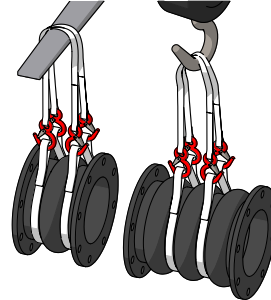

Figure 3: Large Joint Handling

Note: Do not let expansion joint sit vertically on the edge of its flanges for any period of time.

3.0 Prior to Installation:

3.1 Verify System Parameters:

Check the system design parameters to ensure the supplied expansion joint meets the requirements of the system and that the system requirements do not exceed the maximum capabilities of the supplied expansion joint. (Pressure, Temperature, Fluid, expected system movements, etc.)

3.2 Pipe Anchoring/Supports:

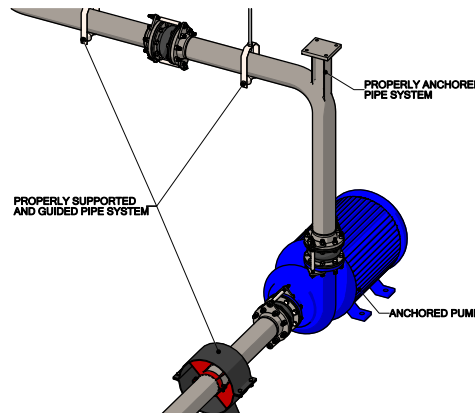

Figure 4: Anchored/Supported System

3.2.1 Anchoring:

Solid anchoring is required wherever the pipeline changes direction, and expansion joints should be located as close as possible to anchor points. If anchor points are not used, the pressure thrust may cause excessive movements and damage the expansion joint.

Note: If the piping system is not properly anchored or anchoring is in question then the use of control units are required to handle the pressure thrust loads experienced in the system.

3.2.2 Supports:

Check the piping supports where the rubber expansion joint will be installed. Piping to and from the location of the rubber expansion joint must be properly supported and guided to ensure that the weight of the piping is not transferred to the expansion joint.

3.3 Pipe Alignment:

Inspect the system for alignment as stated in the procedures listed below for Axial, Lateral, Angular and Torsional alignment. Piping misalignment in the system should not exceed a maximum of $\pm 1/8$ " per Fluid Sealing Association (FSA). If the maximum allowable misalignment is exceeded, the piping should be corrected before installation of the expansion joint takes place. *Note: Expansion joint can be constructed with a misalignment built in, contact Proco Products, Inc. for additional information at 800-344-3246.*

3.3.1 Axial Alignment:

To measure for axial misalignment, measure from the inside of one mating flange to the inside of the other, the area in which the expansion joint is to be installed. This measured dimension should correspond to the ordered expansion joint's face-to-face dimension otherwise an axial misalignment is indicated.

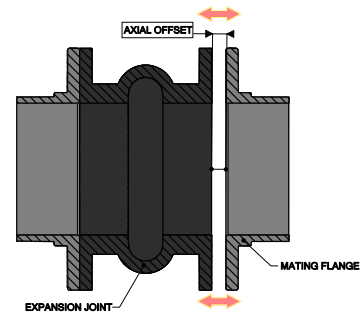

Figure 5: Axial Misalignment

3.3.2 Lateral Alignment:

To measure for lateral misalignment, place a level on the outside edge of the mating flanges and measure the distance across. Repeat the measurement at least 3 times to obtain a total of 4 measurements evenly distributed around the circumference of the mating flanges (6-8 total measurements for large ID expansion joints). Any variation in the measured dimensions and an inconsistency in the level, indicates a lateral misalignment.

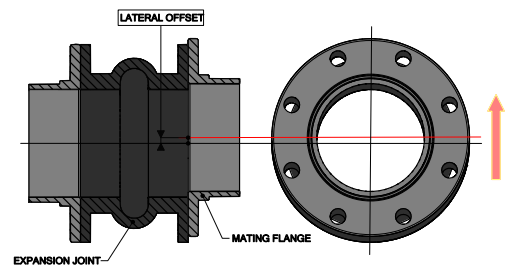

Figure 6: Lateral Misalignment

3.3.3 Angular Alignment:

To measure for angular misalignment between mating flanges, measure from the edge of one flange to the same corresponding spot on the opposing flange. Record this value and then repeat the same measurement on the opposite side of the flanges (180° from the initial measurement). Repeat these measurements to obtain a total of at least 4 paired measurements evenly distributed around the circumference of the flanges. Compare the measured dimensions and any variation in the measured dimensions indicates that the mating flanges are not parallel and are angularly misaligned.

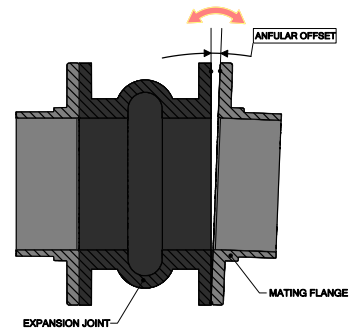

Figure 7: Angular Misalignment

3.3.4 Torsional Alignment:

Check the flange bolt pattern on each mating flange and ensure the bolt holes on each flange line up to each other. Any variation as shown in Figure 8 will indicate a torsional misalignment.

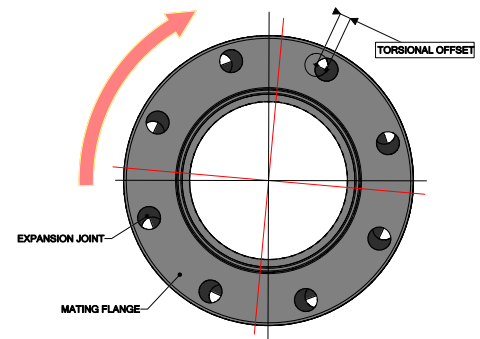

Figure 8: Torsional Misalignment

3.4 Concurrent Movement Calculation:

Concurrent movements are developed when two or more movements in a pipe system occur at the same time. To perform the calculation for concurrent movement when a pipe system has more than one movement, use the following formula:

$$\frac{\text{Actual Axial}}{\text{Rated Axial}} + \frac{\text{Actual Lateral}}{\text{Rated Lateral}} + \frac{\text{Actual Angular}}{\text{Rated Angular}} + \frac{\text{Actual Torsional}}{\text{Rated Torsional}} \leq 1$$

Calculation must be < 1 for expansion joint to operate within concurrent movement capabilities.

Note: Lateral offsets can be found in two planes.

3.5 Unpack/Inspect Expansion Joint:

Remove the expansion joint from the packaging and if applicable verify that the tag information corresponds with the point of installation into the system. Check the outer cover and the internal tube or bonded liner depending on the style of expansion joint ordered for any damage before placing in service. The cover and tube/liner are designed to keep harmful materials from penetrating the carcass of the joint. Penetration of the cover or tube/liner by harmful materials can cause premature failure of the expansion joint. If the outer cover and/or inner tube/liner is damaged during unpacking or installation contact Proco Products, Inc. by phone: 209-943-6088, by facsimile: 209-943-0242 or by e-mail: sales@procoproducts.com, to determine a course of action before the expansion joint is placed into service.

4.0 Expansion Joint Installation:

4.1 Installation Precautions:

4.1.1 Adjacent Equipment:

Never install expansion joints that utilize split retaining rings/Integral flanges next to wafer-type check or butterfly valves. Serious damage can result to a rubber expansion joint of this type unless installed against full-faced flanges.

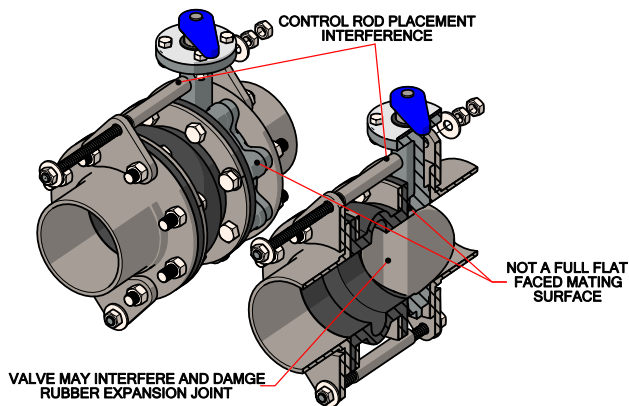

Figure 9: Adjacent Equipment Precaution

4.1.2 Insulating Over Expansion joint:

It is suggested not to insulate over a non-metallic expansion joint. If insulation is required, it should be made removable to permit easy access to the flanges. Removable insulation will facilitate periodic inspection of the expansion joint material and allow for tightening of expansion joint bolts. *(It should be noted that insulation could cause restriction of expansion joint movement and/or excessive heating of the expansion joint material to exceed the maximum rated capability of the expansion joint.)*

4.1.3 Heat Tracing Over Expansion Joint:

Do not use heat tracing over expansion joints.

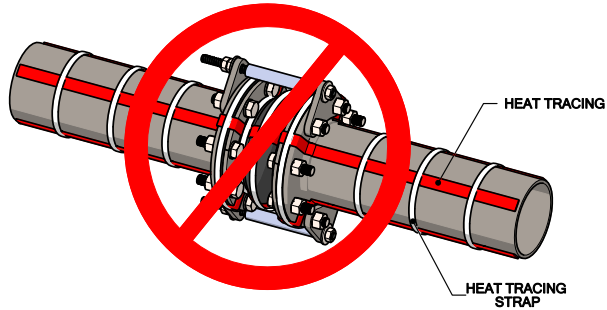

Figure 10: Do Not Heat Trace Over Expansion Joint

4.1.4 Welding Near Expansion Joints:

Take precautions when welding next to or near an expansion joint. Weld splatter can damage the rubber material, thus decreasing overall performance during operation. If welding near a rubber expansion joint, it is suggested that a welding blanket be used to protect against damage.

4.2 Installation Procedures:

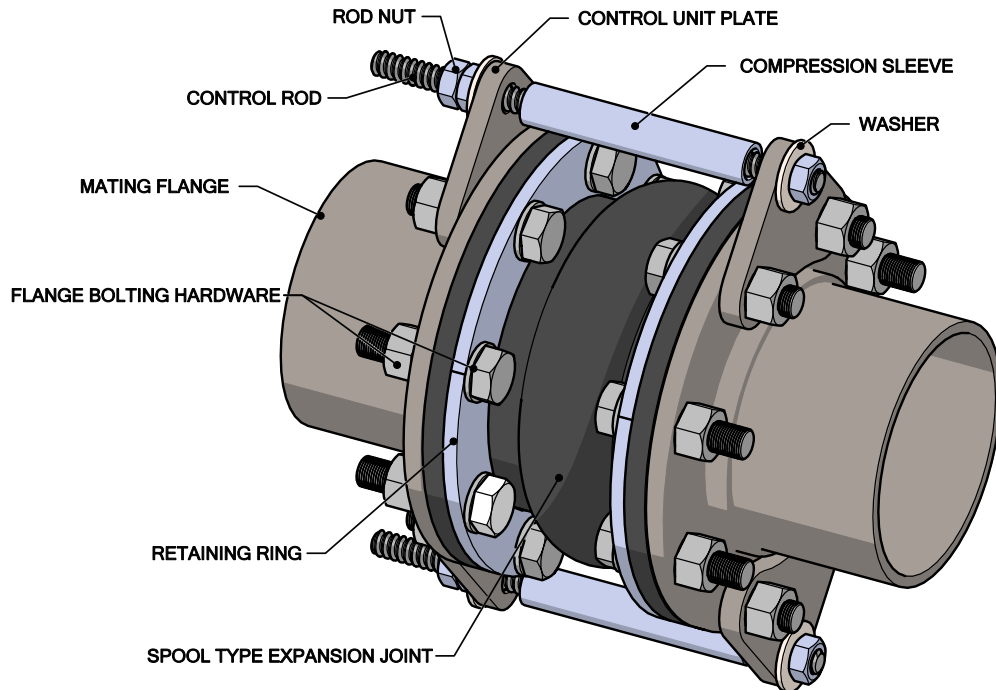

Figure 11: Standard Components of an Expansion Joint Assembly

Step 1: Inspect the mating flanges to ensure that they are clean and free of all foreign matter before installing the rubber expansion joint. A flat face mating flange is preferred. If raised face flanges are to be used, the flange lip is to be no more than 1/16" tall. If the mating flange is plastic or FRP it is recommended to use a stiffener ring to reinforce the mating flange.

Step 2: Place and align the expansion joint into the system. Take care when installing the expansion joint into the system to prevent any damage to the expansion joint, refer to section 2.2 for large joint handling if applicable. To facilitate installation of expansion joints with acceptable misalignment, it is acceptable to use tapered pins to align the expansion joint to the bolt holes on the mating flange to ease installation of flange bolting as shown in Figure 13.

Note: It is acceptable, but not necessary to lubricate the expansion joint flanges with a thin film of graphite dispersed in Glycerin or water to ease disassembly at a later time. (Petroleum lubricants should not be used on rubber expansion joints.)

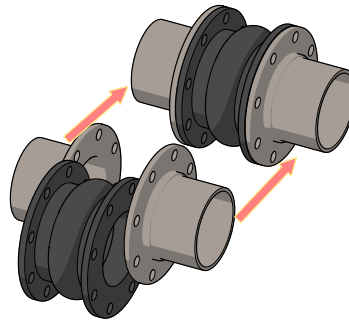

Figure 12: Place Expansion joint Into System

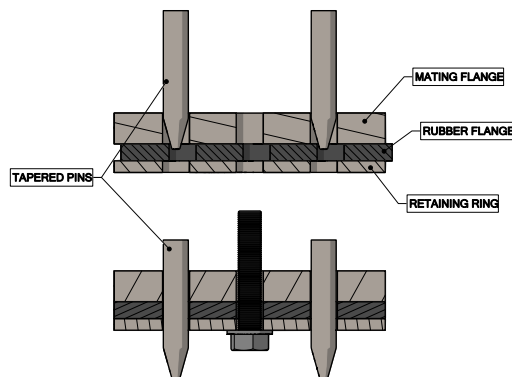

Figure 13: Installing Expansion Joint with Minor Misalignment

Step 3: Add the retaining rings to the expansion joint assembly. The retaining rings have one side beveled. The beveled side at the I.D. of the retaining ring should be installed against the rubber flange. This will prevent the edge of the ring from cutting the rubber flange.

Note: Retaining Rings come in 2 or 4 segmented sets depending on size of expansion joint

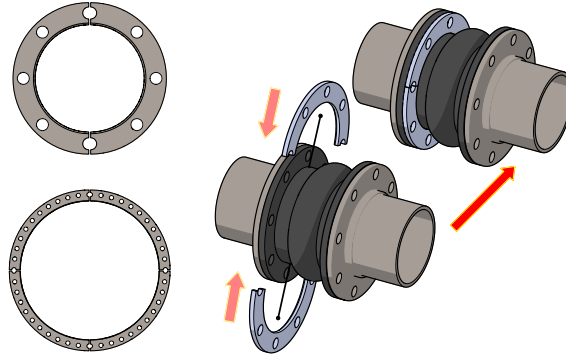

Figure 14: Attach Retaining Rings

Step 4: Secure the retaining rings in place with the flange bolting so that the bolt head and washer are against the retaining rings as shown in Figure 15. Washers must be used at least at the split in the retaining rings or else flange leakage may occur.

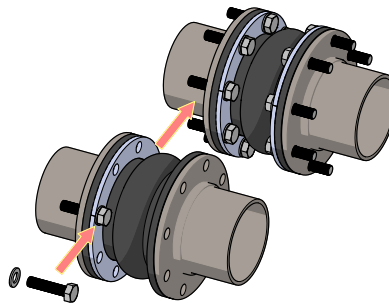

Figure 15: Secure Retaining Rings to Assembly

Step 5: Attach the control rod plates to the outside of the mating flange. The control rod plates should be equally spaced around the circumference of the mating flange.

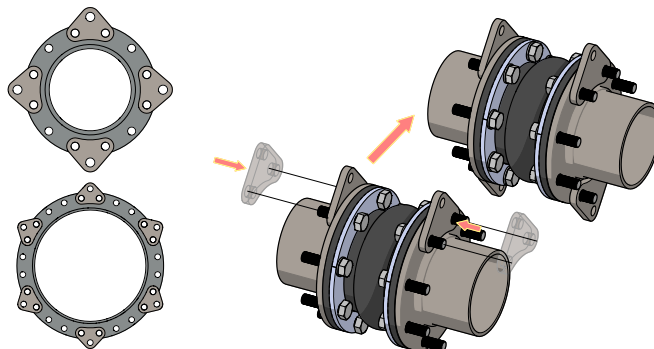

Figure 16: Attach Control Rod Plates to Assembly

Step 6: Once the expansion joint and control rod plates are in place tighten all bolts to a “snug” tight fit before they are torqued. Torqueing should then be accomplished in steps gradually and as evenly as possible around the flange. The bolts should be tightened in an alternating sequence similar to the star pattern shown in Figure 18 to within the proper torque range specified for the style of expansion joint to be installed. The bolts are not considered tight and “locked-on” until the edge of the expansion joint flange bulges out or extrudes slightly. Refer to Appendix A for the proper ranges of torque values for the spool type expansion joints as well as further examples of the proper patterns used for torqueing the flange bolting. The use of stud bolting is acceptable as long as no more than 2-4 threads extend past the nut facing the expansion joint. Excessive amounts of threading extending toward the expansion joint can cause damage to the expansion joint as it expands resulting in a reduced service life and an increased possibility of failure.

Note: Never tighten bolts on a rubber expansion joint to the point where there is contact between the retaining ring and mating flange. This type of tightening will crush the rubber expansion joint and cause premature failure.

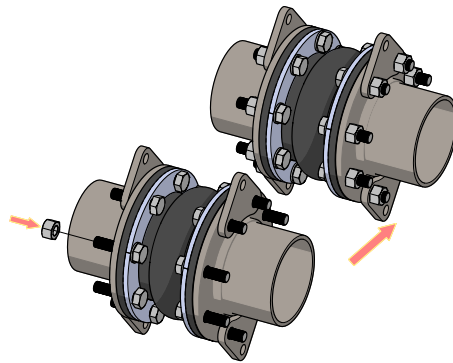

Figure 17: Add Flange Bolting Nuts to Assembly

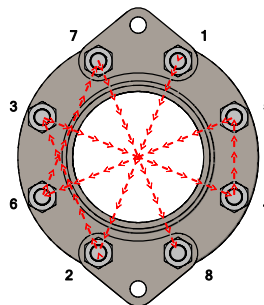

Figure 18: Sample Flange Bolting Torque Pattern

Step 7: Insert the staked control rod with the washer attached through the control rod plate holes. Then secure the additional hardware and compression sleeve to the control rod and control rod plates as shown in Figure 19. Replace flat washers with spherical washers whenever application requires.

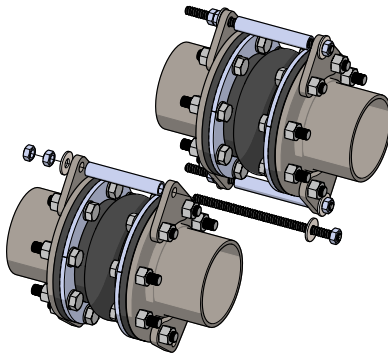

Figure 19: Control Rod with Compression Sleeve Installation

Step 8: When setting control rod gaps and the compression sleeve length, the outer nuts are to be positioned to meet maximum extension requirements and the compression sleeve should be cut to a minimum length that will allow for the maximum compression requirements.

$$\text{Compression Sleeve Length} = \text{Face-To-Face Dimension of Expansion Joint} + \text{Mating Flange thicknesses} - \text{Total Compression Required}$$

The control rod gaps and compression sleeve lengths are to be determined by the project or site engineer. The combined gaps on the control rods are not to exceed the maximum rated movement capabilities of the supplied expansion joint. For unanchored systems there should be no extension gaps in the control rods, all hardware on the control rods should be snug to the control rod plates.

Note: Please contact Proco Products, Inc. by phone: 209-943-6088, facsimile: 209-943-0242, or e-mail: sales@procoproducts.com, if there are any questions as to the rated compression or extension movements.

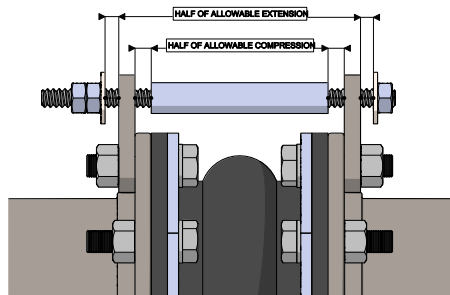

Figure 20: Setting of Control Rod Gap for Anchored System

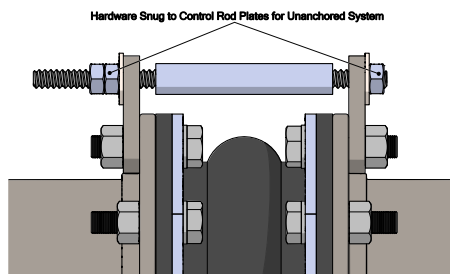

Figure 21: No Control Rod Gap for Unanchored System

5.0 System Testing:

5.1 System Pressure Test:

- 5.1.1 Follow pressure test instructions set by site engineer. Lock down control rod hardware before pressure test as shown in Figure 21. Pressure test should not exceed 1.5 times operating pressure for 10 minutes. Refer to specified drawing for pressure rating and details.

5.2 After Pressure Test

- 5.2.1 After the pressure test is conducted de-pressurize the system and check the flange bolting. Tighten bolts as necessary as bolts may loosen as rubber flange takes a set.

6.0 Operation and Maintenance Procedures:

6.1 Inspection of Rubber Expansion Joint at Shut-Down:

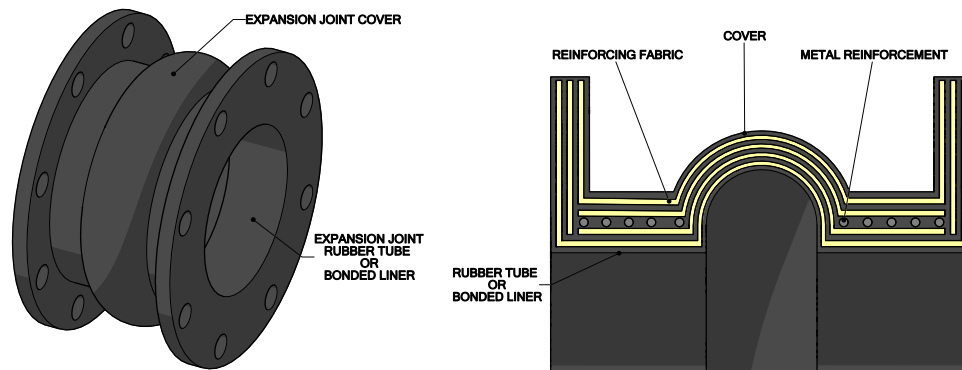

Figure 22: Typical Expansion Joint Make-Up

6.1.1 Cover Inspection:

Rubber expansion joints should be visually inspected at shutdowns. Look for any signs of cracks in the outer cover that shows exposed fabric reinforcement. If fabric reinforcement is exposed, the expansion joint must be replaced.

6.1.2 Tube/Liner Inspection:

If inspection of the internal rubber tube or bonded liner of the expansion joint is possible look for signs of exposed fabric, excessive wear or cracking. If the inner tube or bonded liner show any of these signs, the expansion joint must be replaced.

6.2 Expansion Joint Bolt Check:

Check expansion joint at least one week after start-up to ensure that bolts are tight on expansion joint and control rod assemblies. As any rubber-like material takes a “set” after a period of compression, bolts may loosen; thus resulting in a possible broken seal between the expansion joint and the mating flange. Periodically check bolting to ensure bolts are tight. Tighten as necessary.

Note: Ensure system is de-pressurized before tightening flange bolting.

6.3 Service Conditions:

Make sure the expansion joint operates at the temperature, pressure, vacuum, and movements matching the original requirements. Contact Proco's Customer Service Department by phone: 209-943-6088, facsimile: 209-943-2042, or e-mail: sales@procoproducts.com, if the system requirements exceed those specified.

6.4 Breaking the Rubber Expansion Joint Seal:

In the event a rubber expansion joint is to be removed from the system and put back in service at a later date, the seal between the mating flange and joint will need to be broken. Drive small wooden wedges along the perimeter between the rubber flange and pipe flange. With proper care the connection can be broken without damage to the rubber expansion joint and the adjacent pipe flanges.

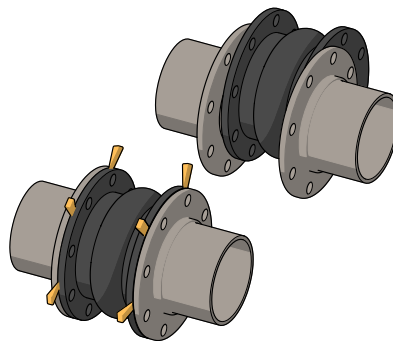



Figure 23: Breaking of Expansion Joint Seal

6.5 Spares:

A rubber expansion joint spare should be put in stock in the event a mechanical failure occurs. Stock one (1) spare for each size purchased. Although these expansion joints are engineered to give long, dependable service, the cost of equipment downtime, in the event of a mechanical failure, can far outweigh the cost of a spare. Spares will be packaged in waterproof crates and prepared for storage.



7.0 Trouble Shooting

7.1 Leaking at the Flange:

- 7.1.1 The flange bolts may need retightening. On the rubber expansion joints the flange bolting should be tight enough to make the edge of the rubber flange bulge slightly between the metal flange and the retaining rings. Ensure system is depressurized before tightening the flange bolting.
- 7.1.2 The surface of the mating flange may be in poor condition. Make sure there are no excessive grooves, scratches or distorted areas.
- 7.1.3 The joint may have been over-extended to such an extent that it has caused the rubber flange to pull away from the mating flange. If so, perhaps limit rods are needed.

7.2 Cracking at Base of Arch or Flange:

Make sure the installed face-to-face dimension is correct so that the joint is not over-extended or over-compressed. Check to see if the pipes are properly aligned so there is no excessive misalignment. Pipes should not be more than 1/8" out of alignment. Check to see if system is properly anchored or if control rods are used. External cracking of cover does not mean failure. This is often caused by exposure to strong sunlight in an extended condition. If cracking extends to the fabric reinforcing member, the expansion joint must be replaced.

7.3 Liquid Weeping through Bolt Holes:

Look for a break in the tube portion of the joint. If there is a crack or a break, the joint must be replaced as soon as possible.

7.4 Excessive Ballooning of Arch:

Ballooning is usually an indication of deterioration of the joint's strengthening members or excessive pressure in the system. Service conditions should be double-checked and a new joint must be installed.



APPENDIX A: Torque Data

Table 1: Spool Type Torque Values	
Size	Approx. Torque Values
1" thru 2"	20 - 40 ft./lbs.
2.5" thru 5"	25 - 60 ft./lbs.
6" thru 12"	35 - 140 ft./lbs.
14" thru 18"	50 - 180 ft./lbs.
20" thru 24"	60 - 200 ft./lbs.
26" thru 40"	70 - 300 ft./lbs.
42" thru 50"	80 - 300 ft./lbs.
52" thru 60"	100 - 400 ft./lbs.
66" thru 72"	200 - 500 ft./lbs.
78" thru 90"	300 - 600 ft./lbs.
96" thru 108"	400 - 700 ft./lbs.
120"	500 - 800 ft./lbs.



APPENDIX A: Torque Data

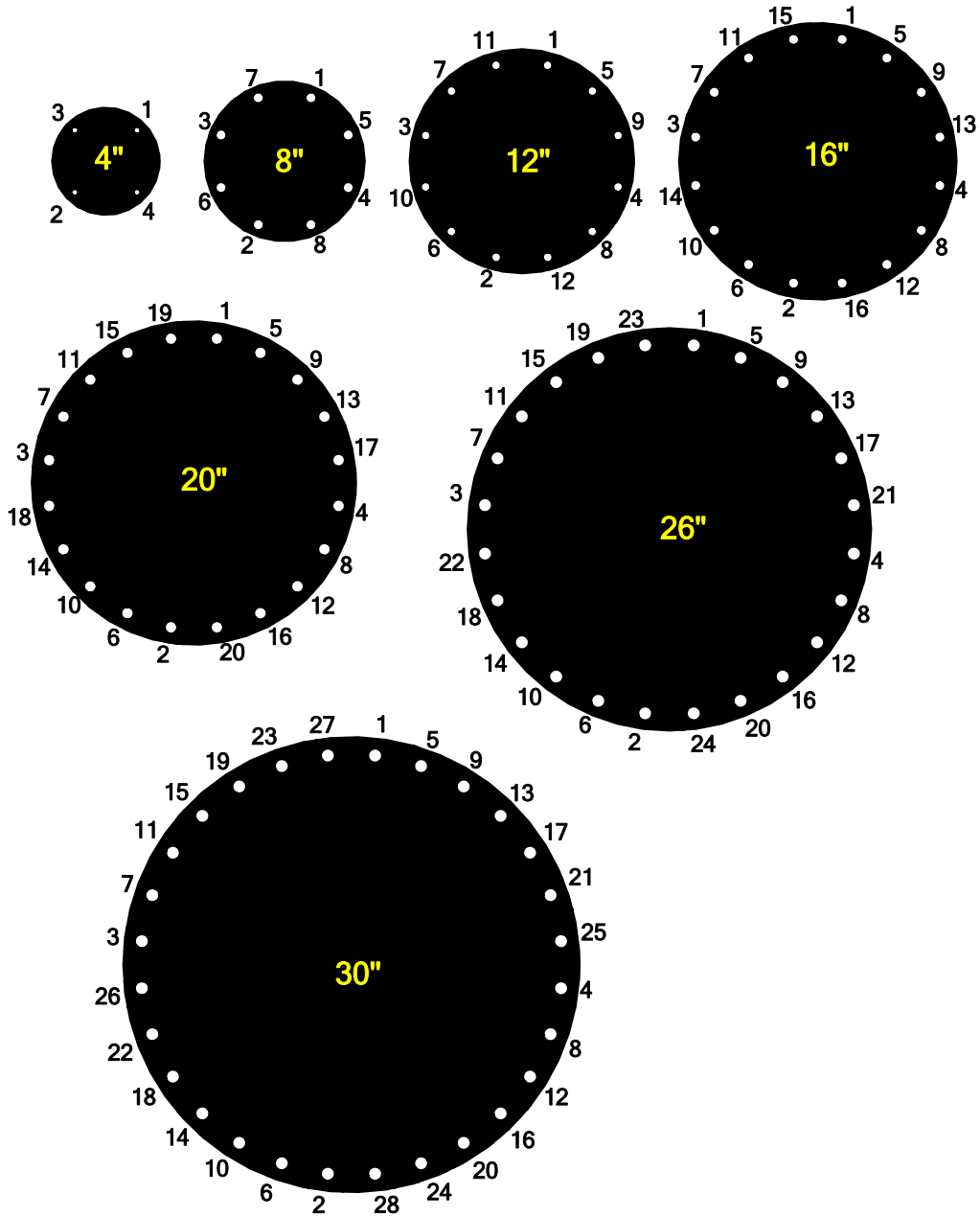

Figure 24: Sample Torque Patterns

APPENDIX B: Installation Record Sheet

Attached are the Installation record sheets, below is an overview of the details of the attached installation record sheets.

Expansion Joint Information:

Proco Style:	<i>Proco Style of Expansion Joint Supplied</i>
Size (Nom. I.D. x F/F Length):	<i>Nominal I.D. x Face-To-Face Length</i>
Purchase Order No.:	
Date of Order/Shipment:	
Drawing Number:	
Tag No.:	

System Installation Information

- Installation Date: *Date of Installation*
1. Medium Gas/Liquid/Steam: *Type of Fluid and the State of the Fluid in the System*
 2. Operating Pressure: *Operating Pressure of the System*
 3. Surge Pressure/Duration: *Surge Pressure Experienced in the System and Duration*
 4. Operating Temperature: *Operating Temperature of the System*
 5. Surge Temperature/Duration: *Temperature at Surge Pressure and Duration*
 6. Confirm Expected Movements in the System:
 - a. Axial Compression: *Expected Axial Compression for Expansion Joint to Compensate*
 - b. Axial Extension: *Expected Axial Extension for Expansion Joint to Compensate*
 - c. Lateral Deflection: *Expected Lateral Deflection for Expansion Joint to Compensate*
 - d. Angular Deflection: *Expected Angular Deflection for Expansion Joint to Compensate*
 - e. Torsional Rotation: *Expected Torsional Rotation for Expansion Joint to Compensate*
 7. Verify System is Properly Anchored/Guided: *Verify Anchors and Guides in the System*
- Notes: _____
-
8. Distance to Nearest Anchor Point (each end): *Measure the Distance to the Nearest Anchor Points*
 9. Mating Flange Rating/Type (RF/FF): *Rating and Type of Mating Flanges*
 10. Verify Mating Flanges are Parallel: *Verify that the Mating Flanges are Parallel to each other*
 11. Verify Centerline Alignment: *Verify that the Point of Installation is Properly Aligned to the Centerline*
 12. Verify Axial Alignment: *Verify Axial Alignment for the Point of Installation*
 13. Verify Lateral Alignment: *Verify Lateral Alignment for the Point of Installation*
 14. Verify Angular Alignment: *Verify Angular Alignment for the Point of Installation*
 15. Verify Torsional (Rotational) Alignment: *Verify Torsional Alignment for Point of Installation*
 16. Installation Orientation (Horiz/Vert): *Record Installation Orientation of Expansion Joint*
 17. Installed Face-To-Face Length (measured in 4 positions):
 - a. 3 O'clock Flange Position: *Measure Face-To-Face Dimension at Specified Flange Position*
 - b. 6 O'clock Flange Position: *Measure Face-To-Face Dimension at Specified Flange Position*
 - c. 9 O'clock Flange Position: *Measure Face-To-Face Dimension at Specified Flange Position*
 - d. 12 O'clock Flange Position: *Measure Face-To-Face Dimension at Specified Flange Position*
 18. Average Bolt Torque: *Record Average Bolt Torque used to Secure Expansion Joint to Mating Flanges*
 19. Control Rods:
 - a. Number of Control Rods: *Record Number of Control Rods Used*
 - b. Control Rod Gap/Compression Sleeve Length: *Record the Control Rod Gap/Sleeve Length*
- Notes: _____
-

Installation Record Sheet



Expansion Joint Information:

Proco Style:	
Size (Nom. I.D. x F/F Length):	
Purchase Order No.:	
Date of Order/Shipment:	
Drawing Number:	
Tag No.:	

System Installation Information

Installation Date: _____

1. Medium Gas/Liquid/Steam: _____
2. Operating Pressure: _____
3. Surge Pressure/Duration: _____
4. Operating Temperature: _____
5. Surge Temperature/Duration: _____
6. Confirm Expected Movements in the System:
 - a. Axial Compression: _____
 - b. Axial Extension: _____
 - c. Lateral Deflection: _____
 - d. Angular Deflection: _____
 - e. Torsional Rotation: _____
7. Verify System is Properly Anchored/Guided: _____

Notes: _____

8. Distance to Nearest Anchor Point (each end): _____
9. Mating Flange Rating/Type (RF/FF): _____
10. Verify Mating Flanges are Parallel: _____
11. Verify Centerline Alignment: _____
12. Verify Axial Alignment: _____
13. Verify Lateral Alignment: _____
14. Verify Angular Alignment: _____
15. Verify Torsional (Rotational) Alignment: _____
16. Installation Orientation (Horiz/Vert): _____
17. Installed Face-To-Face Length (measured in 4 positions):
 - a. 3 O'clock Flange Position: _____
 - b. 6 O'clock Flange Position: _____
 - c. 9 O'clock Flange Position: _____
 - d. 12 O'clock Flange Position: _____

18. Average Bolt Torque: _____
19. Control Rods:
 - Number of Control Rods: _____
 - Control Rod Gap/Compression Sleeve Length: _____

Notes: _____

Proco Products, Inc.
2431 North Wigwam Dr.
Stockton, CA 95205
Phone: 800-344-3246
Fax: 209-943-0242
Email: sales@procoproducts.com